

Kubota

For Long Life

EASY SELF MAINTENANCE

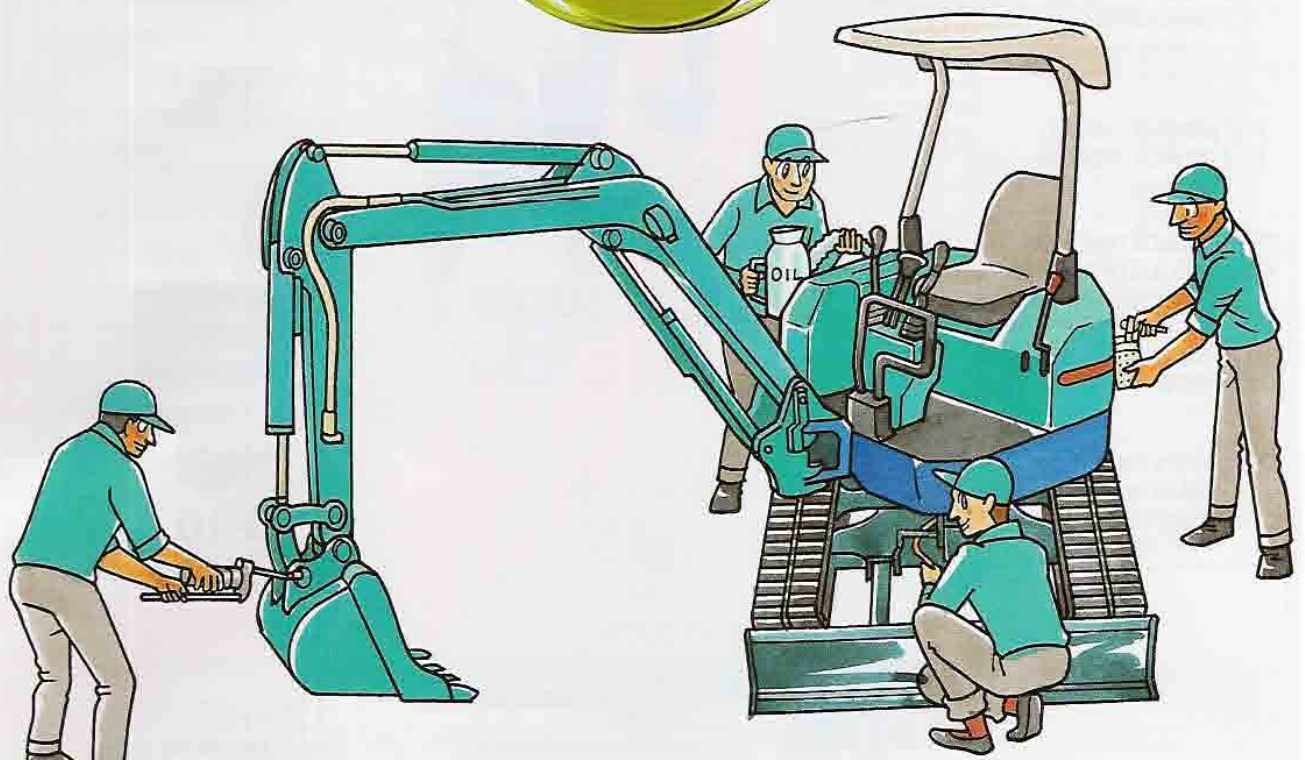

U-Series: U-10, 15, 20, 35, 45



Code No.97899-E

We congratulate you on your new Kubota excavator and express our deep appreciation that you have decided for our product. This excavator is a quality product of Kubota's engineering and production performance, manufactured with high quality materials under strictest quality control. With this machine you can rely on long time satisfactory work performance. To keep your machine for long life, proper maintenance is also a essential care point. This manual has been compiled to visualize why, how and where to care your machine. We sincerely hope you would easily access those required maintenance items according to this manual. Taking care of your machine is partly Kubota's job and partly your Kubota Dealer's job. And your self maintenance is also very important to keep your machine for long life. 'Service for Life' is a key word for our product support. So utilize this manual and also feel free to contact your Kubota Dealer if in need. Thank you very much.

MACHINE & BODY ATTACHMENT

17 FRONT GREASING POINTS

18 TEETH BEARING PILOT VALVE GREASING
VARIABLE TRACK FRAME GREASING

19 FRONT IDLER & TRACK ROLLER

20 TRACK TENSION ADJUSTMENT

21 BUCKET TEETH & SIDE CUTTER

22 BOLTS & NUTS CHECKING OF MUFFLER ROPS/FOPS CAB & CANOPY



HYDRAULIC SYSTEM

12 HYDRAULIC OIL

13 HYDRAULIC RETURN FILTER & SUCTION FILTER

14 TRAVEL REDUCTION CASE GEAR OIL

15 PILOT FILTER

ENGINE

- 1 ENGINE OIL
- 2 OIL FILTER
- 3 COOLANT
- 4 RADIATOR
- 5 FAN BELT TENSION
- 6 AIR CLEANER ELEMENT
- 7 FUEL FILTER
- 8 WATER SEPARATOR
- 9 FUEL HOSE
- 10 BATTERY
- 11 WIRE HARNESS & FUSES



U-35



U-45

16 PILOT VALVE SCREEN CLEANING

CONTENTS

ENGINE

1. ENGINE OIL	-----	P3-F
2. OIL FILTER	-----	P3-P
3. COOLANT	-----	P5-P
4. RADIATOR	-----	P5-P
5. FAN BELT TENSION	-----	P7-P
6. AIR CLEANER ELEMENT	-----	P7-P
7. FUEL FILTER	-----	P9-P11
8. WATER SEPARATOR	-----	P9-P11
9. FUEL HOSE	-----	P11-P12
10. BATTERY	-----	P11-P12
11. WIRE HARNESS & FUSES	-----	P13-P14

HYDRAULIC SYSTEM





12. HYDRAULIC OIL	-----	P15-P16
13. HYDRAULIC RETURN FILTER & SUCTION FILTER	-----	P15-P16
14. TRAVEL REDUCTION CASE GEAR OIL	-----	P17-P18
15. PILOT FILTER	-----	P17-P18
16. PILOT VALVE SCREEN CLEANING	-----	P19-P20



MACHINE BODY & ATTACHMENT

17. FRONT GREASING POINTS	-----	P21-P22
18. TEETH BEARING, PILOT VALVE GREASING (VARIABLE TRACK FRAME GREASING)	-----	P21-P22
19. FRONT IDLER & TRACK ROLLER	-----	P23-P24
20. TRACK TENSION ADJUSTMENT	-----	P23-P24
21. BUCKET TEETH & SIDE CUTTER	-----	P25-P26
22. BOLTS & NUTS CHECKING OF MUFFLER ROPS/FOPS & CAB CANOPY	-----	P25-P26

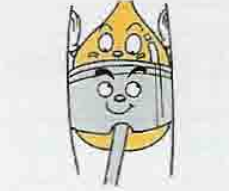
This manual has been compiled based on U-20. Some maintenance procedure and specifications may possibly be different according to the models. For details, you are required to refer to the specific Operator's manual.

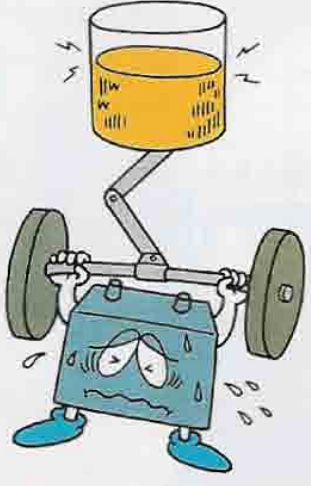
ENGINE

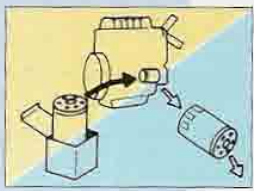
Item	Purpose	Fail symptom without maintenance
<p>1</p> <p>ENGINE OIL</p> 	<div style="display: flex; flex-wrap: wrap;"> <div style="width: 50%; text-align: center;"> <p>Lubricating function</p>  </div> <div style="width: 50%; text-align: center;"> <p>Sealing function</p>  </div> <div style="width: 50%; text-align: center;"> <p>Cooling function</p>  </div> <div style="width: 50%; text-align: center;"> <p>Cleaning function</p>  </div> </div>	<p>Shortage or deterioration of engine oil causes bearing seizure, severe damage or shorten life expectancy.</p> 

<p>2</p> <p>OIL FILTER</p> 	<p style="text-align: center;">Filtration</p> 	<p>Contaminated fuel causes loss of engine power and oil line clogging or even fatal damage.</p> 
--	---	---

Inspection method



Oil gauge dip stick
Oil filling port



Oil amount

Securely check oil level between the allowable range.



CAUTION

For safe maintenance !

To avoid personal injury :

- Stop the engine before checking the oil level.

Adjusting/Refill/Change



Hydraulic oil quantity

L (US gal.)

U-10	U-15	U-20	U-35	U-45
0.66 (2.5)	0.69 (2.6)	1.06 (4.0)	1.19 (4.5)	2.11 (8.0)

- Change interval...initial/ 50hrs. after/250hrs.



Engine oil filter



Wrench



- Code No. for engine oil filter cartridge

U-10,U-15	15841-3243-0
U-20,35	15241-3209-0
U-45	17321-3243-0

■ Replacing Engine Oil Filter

1. Replace the oil filter cartridge at the same time as engine oil change.
2. Remove the cartridge with the supplied filter wrench.
3. Apply some oil on the O-ring of the new oil filter cartridge. Then tighten the oil filter cartridge by hand.
4. Fill engine oil to the specified level.
5. Let the engine run for approx.5min.and make sure that the engine oil control lamp does not light up. Then stop the engine.
6. The engine oil level will lower to fill the filter to capacity after the engine has been started. It is necessary to add oil.

- Change interval...initial/ 50hrs. after/250hrs.

ENGINE

Item	Purpose	Fail symptom without maintenance
------	---------	----------------------------------

3 COOLANT

Cooling function

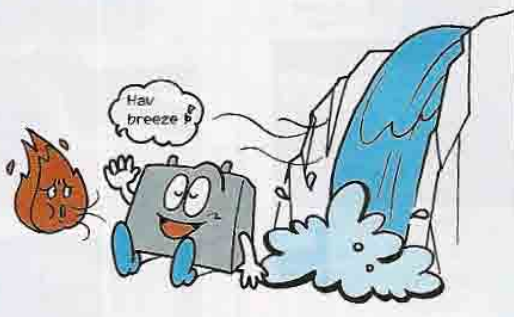

Causes of engine overheat or severe damage.

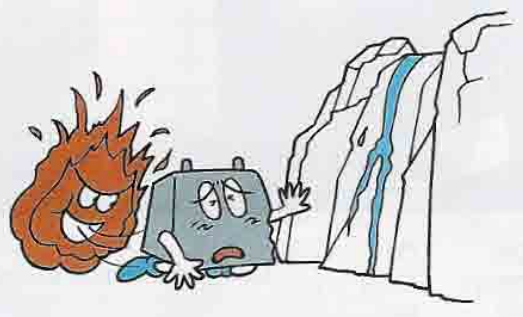

Anti-freeze

Anti-corrosion

Freezing of coolant can cause engine damage. Improper mixture ratio causes freezing in winter or engine overheat in summer.

Anti-freeze
Anti-corrosion

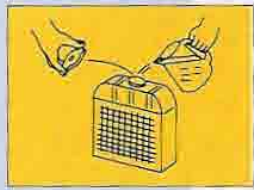
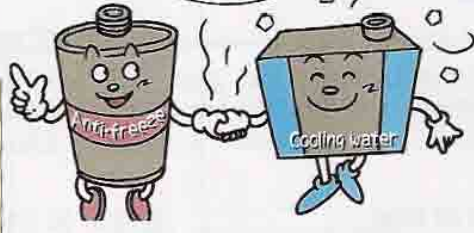

4 RADIATOR

Cooling function

Heat exchange



Air flow is restricted

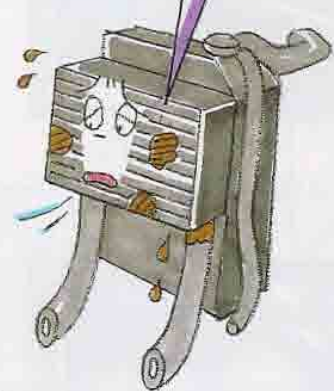

IMPORTANT

- To prevent engine overheating, radiator and oil cooler fins and ribs must be clean in order to allow free flow of air through the cooling elements.

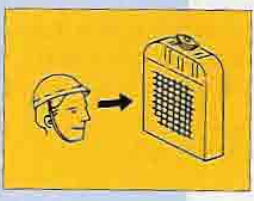

Inspection method

Adjusting/Refill/Change



Reserve tank



Evaluate and compare the color of anti-freeze. New anti freeze will have a green color.



Quantity of coolant in reserve tank L (US gal.)

U-10,15,20	0.5(0.13)
U-35,45	1.0(0.26)

Quantity of coolant in radiator L (US gal.)

U-10	3.0(0.79)
U-15,20	3.5(0.92)
U-35	4.5(1.19)
U-45	5.9(1.56)



CAUTION

For safe maintenance !

To avoid personal injury:

- Move and park the excavator on even ground.
- Make sure that the engine is turned off.
- Do not remove the radiator cap until coolant temperature is below its boiling point.

Then loosen cap slightly to the stop to relief any excess pressure before removing cap completely

- Check the coolant level in the reserve tank only after the engine has cooled down.



Oil cooler



Remove dust and sand by using compressed air.

1. Check if the fins and ribs are clogged. If so, clean with compressed air or steam.
2. Check the rubber hoses for damage and replace if cracked or weathered. Check if the hose clamps are tight properly



CAUTION

For safe maintenance !

To avoid personal injury :

- Always stop the engine before checking the radiator.
- Wear eye protection when cleaning with compressed air.

Radiator hose

- Periodic inspection interval...200hrs.
- Change interval...2years

ENGINE

Item

Purpose

Fail symptom without maintenance

5

**FAN
BELT
TENSION**

Electricity generation

Cooling function

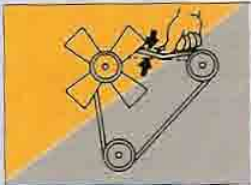
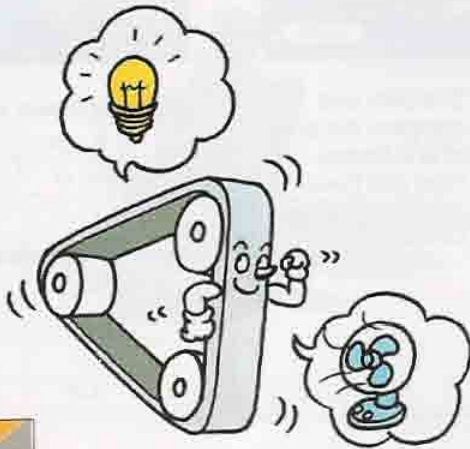

Stretching, cracking, peeling, seizure, and wear can cause engine overheating.

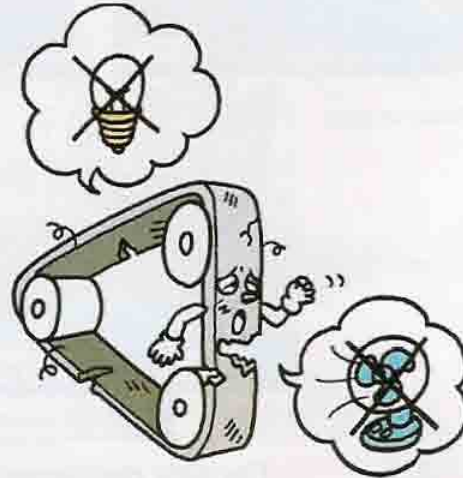

6

**AIR
CLEANER
ELEMENT**

Air filtration

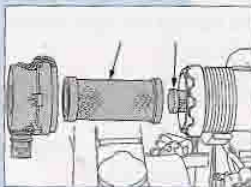

Causes of engine power loss or excessive black smoke. Severe damage of engine parts.



IMPORTANT

- Should the machine be used in extreme dusty areas, the air filter element must be inspected and cleaned more frequently than specified in the maintenance periods.
- The air filter has a dry element, keep it free from oil.
- Do not run the engine without the air filter properly installed.

Inspection method

1. Press the fan belt down in the middle, with a force of approx. 5kg(11lbs.). The belt tension is correct if it deflects about 7mm(0.28in.). To adjust the belt tension, loosen bolt A and B and shift the generator C in the direction shown by the arrow.
2. Replace the fan belt if worn out, cracked or torn.

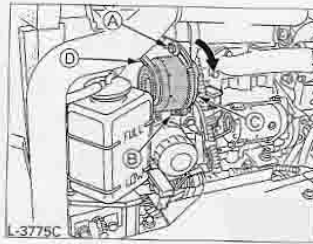

Fan Belt



Damaging sample

burned Coming off Crack



CAUTION

For safe maintenance !

To avoid personal injury :

- First stop the engine.
- After servicing, make sure to secure the belt cover in its original position.

Adjusting/Refill/Change

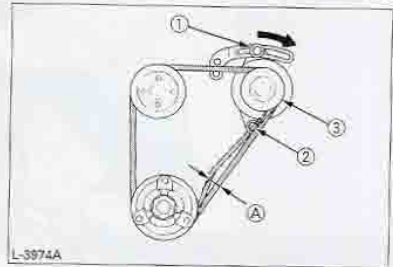
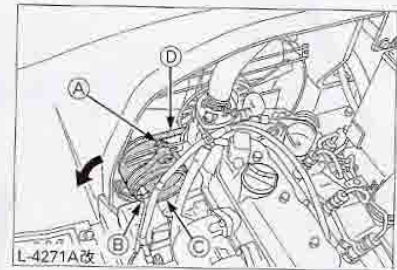

IMPORTANT:

- If the engine is run with a loose fan belt, the belt could slip and cause overheating of the engine or insufficient battery charge. Check fan belt tension regularly. Should the fan belt snap or jump out, the lamp for battery charge will light up. Stop the engine immediately.

■ Periodic inspection interval...200hrs



Outer element

Inner element



Outer element

Inner element

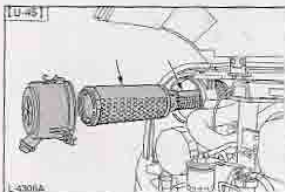

■ Inspection and cleaning of the air filter element

Open the engine cover and remove the dust cover. Remove the wing nut and take out outer element, check and clean if necessary. During reassembly, take care to install the dust cup so that its TOP mark (Arrow) faces up-wards. Do not remove the inner element.

CAUTION

Do not remove the inner element when checking outer element.

For safe maintenance !

- To avoid personal injury:
- Wear eye protection.

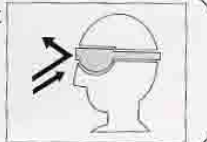

Dirty filter

New

After 600 hours use



- Inspection & cleaning interval...other element 200hrs.
- Change interval...Other & Inner element 1000hrs.

ENGINE

Item

Purpose

Fail symptom without maintenance

7

FUEL FILTER

Fuel filtration

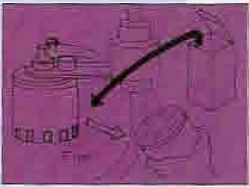

- Engine power loss.
- Severe damage of engine components.

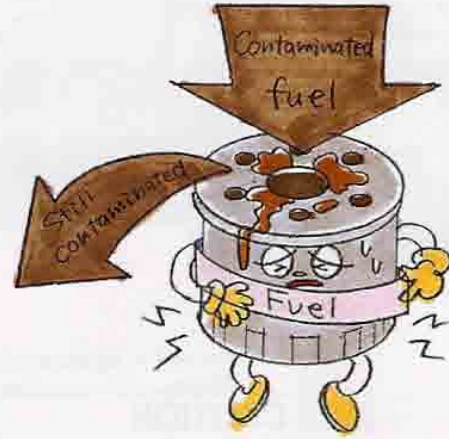

8

WATER SEPARATOR

Water separation in fuel

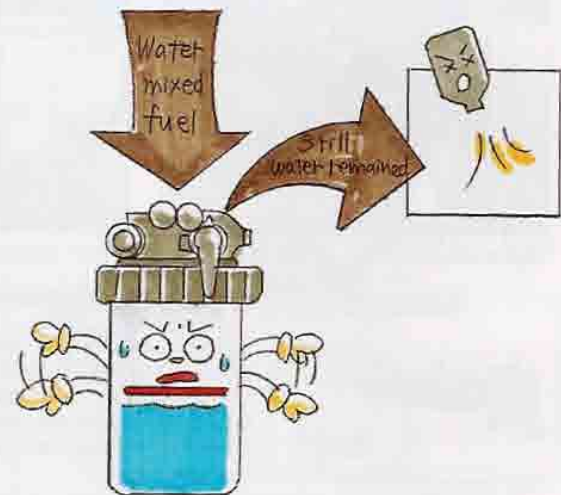
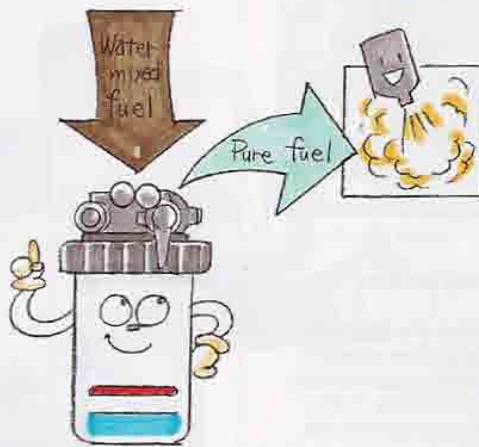

- Water caused rust inside the fuel system components, causing abnormal function.
- Engine won't start.

Inspection method



U-20

Use filter wrench



CAUTION

For safe maintenance !
To avoid personal injury :
 ●Keep open fire away.

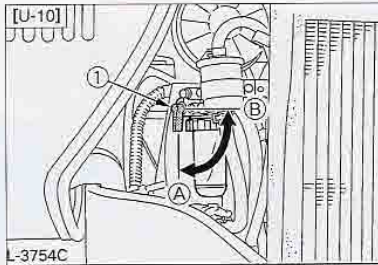

L-3754C

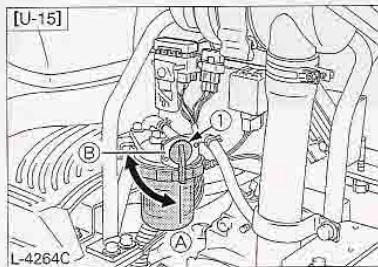

L-4264C

● Code No. for fuel filter element

U-10	15231-4356-0
U-15	RA211-5128-0
U-20,35,45	15221-4317-0

Adjusting/Refill/Change

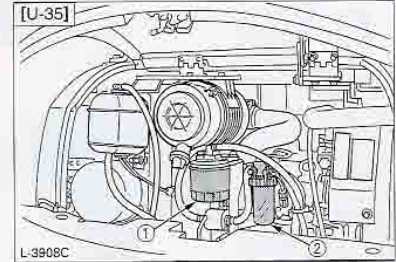

L-3908C

- 1) Fuel filter
 2) Cock of water separator
 A) "Closed"
 B) "Open"

1. Close the cock of the water separator. Remove the filter with the supplied filter wrench.
2. Apply a light film of fuel to the seal of the new filter and turn in tightly by hand.
3. Open the cock of the water separator again.

- Inspection interval...U-10:50hrs.
 U-15:100hrs.
- Change interval...500hrs.



U-20

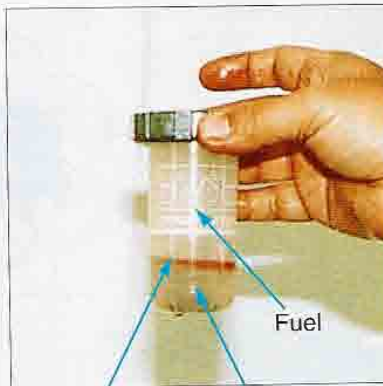

Red ring

Water



CAUTION

For safe maintenance !
To avoid personal injury :
 ●Before draining the fuel tank , be sure to stop the engine.
 ●Do not smoke during inspection.

● Code No. for the Water Separator element

U-20	RB101-5128-0
U-35,45	15831-4338-0

[U-35] Fuel tank drain port

Remove the cover on the right side of the swing frame, remove the drain plug at the bottom of fuel tank and open the drain cock.

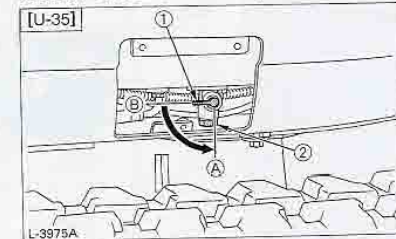

L-3975A

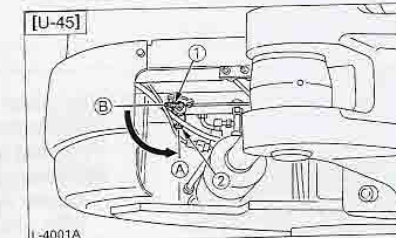

L-4001A

- 1) Drain cock
 2) Drain plug
 A) "Open"
 B) "Closed"

- Water inspection interval...500hrs.
- Fueltank drain...50hrs

ENGINE

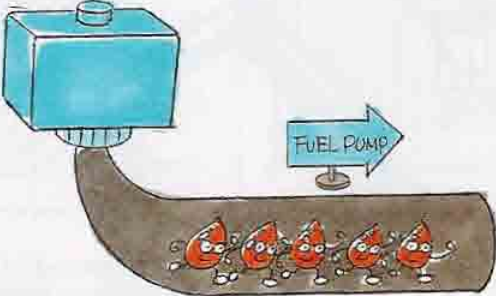
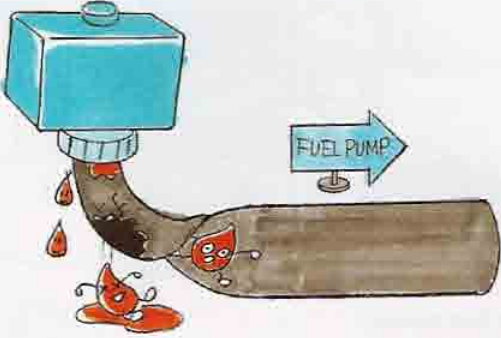
Item	Purpose	Fail symptom without maintenance
<p>9</p> <p>FUEL HOSE</p> 	<p>Fuel line</p> 	<p>Engine won't start or fuel leakage cause engine to stop.</p>  <ul style="list-style-type: none"> ● Hoses may be kink and fuel clogs. ● Hose damages. ● Clamp loosens. <p>These causes engine malfunction.</p>

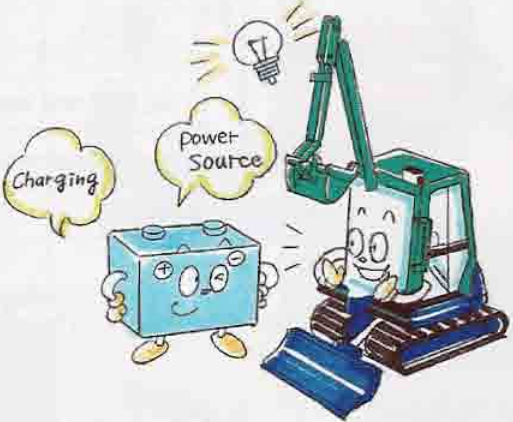
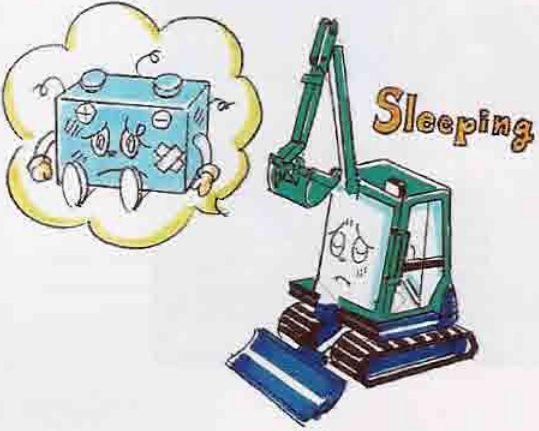
<p>10</p> <p>BATTERY</p>	<p>Charging Power source for lights</p> <p>Power source for system control</p> 	<p>Evaporation of battery electrolyte shortens battery life and can results in engine start failure.</p> 
--	---	---



CAUTION

For safe maintenance !

To avoid personal injury :

- Battery contains sulfuric acid which can cause severe burns. Avoid all contact with skin, eyes or clothing.
- Before inspection or dismantling the battery, be sure to turn off the engine and turn the starter switch to the "OFF" position.
- When removing the battery, always disconnect the negative ground cable first. The reverse when installing a battery, always connect the ground cable last. This prevents a possible explosion caused by sparks.
- Always wear eye protection when working with the battery.

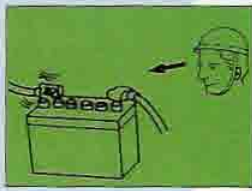

Inspection method

Adjusting/Refill/Change

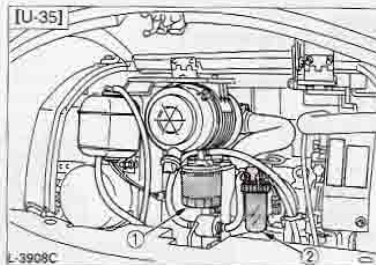

1)Fuel filter 2)Water separator

Replace fuel lines when damaged.
Change every 2 years even if not found damaged.



Tighten hose band if found loosened.

■ Inspection interval...200hrs.

● Change interval...Every 2 years

Battery maintenance and long storage

1. Make sure each electrolyte level is the bottom of vent wells, if necessary add distilled water (in a well-ventilated area).
2. Clean the battery +.-terminals with wire brush and remove rust and dirt by sand-paper. Tighten terminal wire cable after applying grease
3. To charge the battery, connect the battery positive terminal to positive and negative to negative.
4. When the specific gravity of electrolyte become between 1.27and1.29,charge has completed.
5. When renew the battery, use one of equal specifications.
- 6.In case of long storage, disconnect negative terminal or dismount battery from the machine.

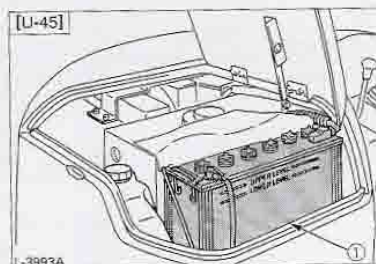
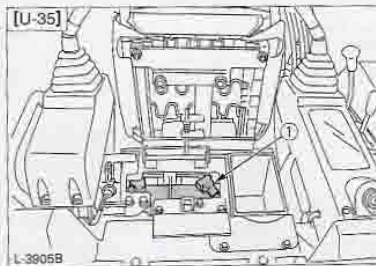
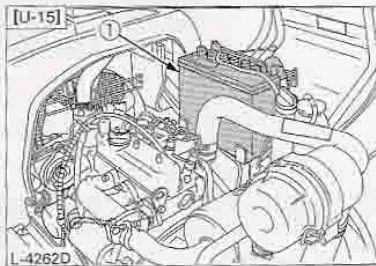

1. Check the battery fluid level and add distilled water if necessary.
2. Should battery fluid be spilt, fill with sulfuric acid solution of the same concentration.
3. Clean the battery caps (ventilation holes)also.



■ Inspection interval...50hrs.

ENGINE

Item

Purpose

Fail symptom without maintenance

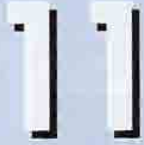

WIRE HARNESS & FUSES

Wire harness: Send electric current.
Fuse: Prevention of excessive current flow.

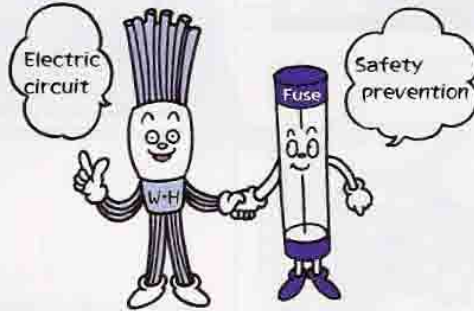

Damaged to wire harness can causes short circuit or even fire.
Improper fuse can causes damages to electric components by excessive current.

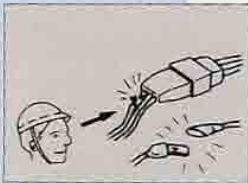
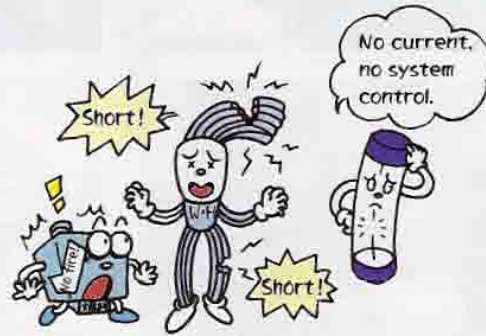

[U-10]

No.	capacity	circuit
1	15A	Fuel cut solenoid
2	10A	Working lamp, Horn
3	5A	Hour meter, Fuel pump, Control lamps, Regulator
4	5A	Timer relay
5	5A,10A,15A	Spare fuses

[U-15]

No.	capacity	circuit
1	15A	Fuel cut solenoid
2	10A	Timer relay
3	10A	Unload valve, Control lamps
4	10A	Horn, working light

[U-20]

No.	capacity	circuit
1	15A	Fuel pump, Horn, Working light, Acceleration valve
2	3A	Unload valve
3	3A	Alternator, Meter panel
4	3A	Timer relay (Engine stop)
5	15A	Fuel cut solenoid
	3A,15A,15A	Spare fuses

[U-35,45]

No.	capacity	circuit
1	15A	Horn (U-45 only)
2	5A	Unload valve, Acceleration valve
3	5A	Fuel pump, Alternator
4	15A	Horn, Working light
5	5A	Timer relay (Engine stop)
6	5A	Meter panel, Check relay
7	15A	Cigarette lighter
8	15A	Cabin equipments
9	10A	Spare power supply (Through main switch)
10	5A	Spare power supply (Directly from battery)
11	15A	Fuel cut solenoid
	5A,10A,15A	Spare fuses

Inspection method

Capacity of the slow blow fuse

U-10,15	30A
U-20	40A
U-35,45	50A

- 1) Slow blow fuse
- 2) Fuse box

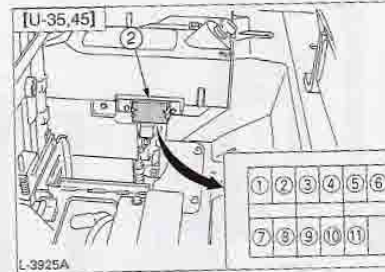
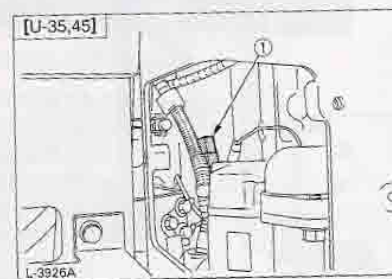
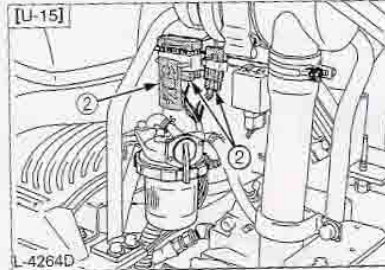
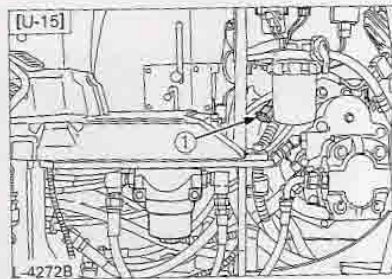
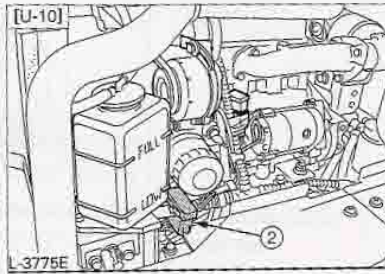
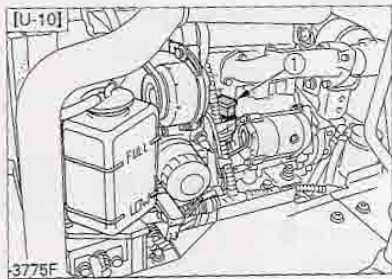

CAUTION

For safe maintenance !
 Stop engine to inspect.
 Disconnect battery negative cable terminal before repairing electric circuit.

Adjusting/Refill/Char

Found any trouble, contact Kubota dealer.



Kubota Dealers Certified Technician



Change to specified fuse only.



■ Inspection interval...Daily

HYDRAULIC SYSTEM

Item	Purpose	Fail symptom without maintenance
------	---------	----------------------------------

12

HYDRAULIC OIL

Power transfer media to actuators.

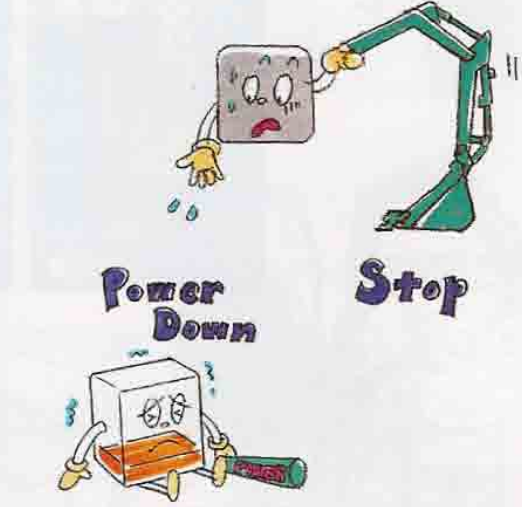
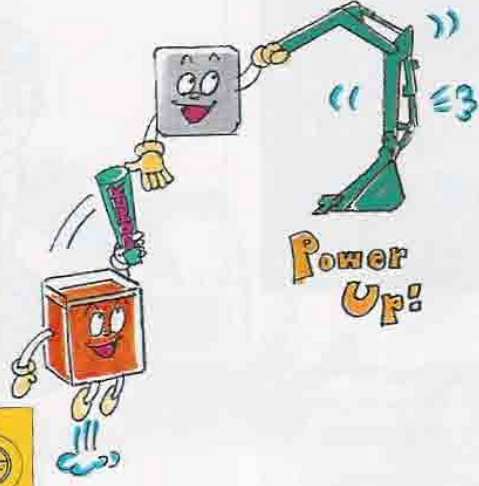

Loss of power transfer.

13

HYDRAULIC RETURN FILTER & SUCTION FILTER

Oil Filtration.

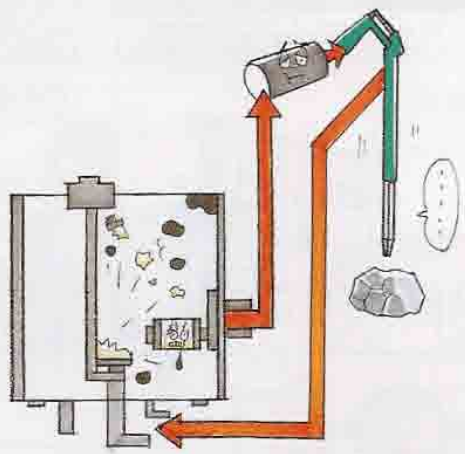
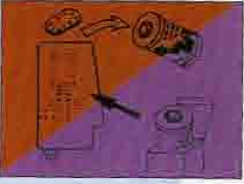
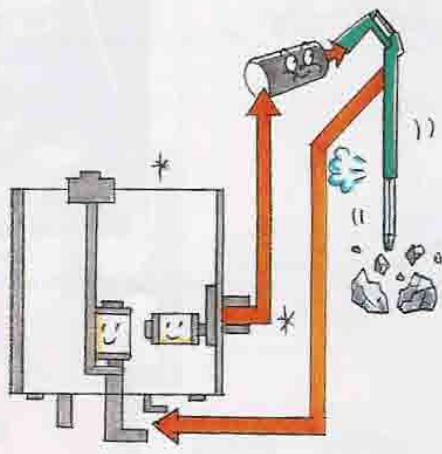

Clogged filter causes malfunction of hydraulic system components.

Inspection method

Adjusting/Refill/Change



Oil level should be in the middle of the sight gauge.

checking oil temp
10-30C° (50~86°F)

Machine position when checking oil level.

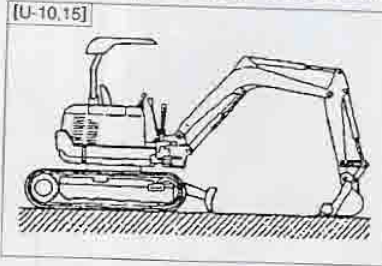

Open tank with breather

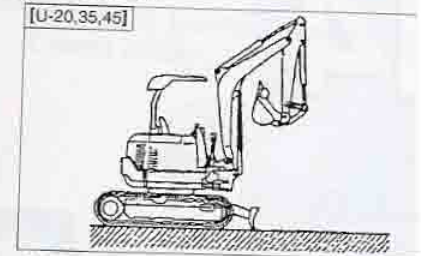

Closed tank : Check oil amount after tightening the tank plug



CAUTION

For safe maintenance !

To avoid personal injury :

- Wait long enough for the hydraulic fluid
- to cool down. Then begin with the change of the hydraulic fluid.

Hydraulic oil quantity

	U-10	U-15	U-20	U-35	U-45
Full	17(4.49)	23(6.08)	33(8.72)	56(14.8)	95(25.0)
Full	14(3.7)	14(3.7)	20(5.28)	39(10.3)	71(18.7)

■ Inspection interval...Daily

● Change interval.....Every1000 hr

Interval of Hydraulic oil check for machines with hydraulic breakers

Oil replacement according to operating hours.

	Hydraulic oil	Return filter	Suction filter
Normal excavator work	every 1000 hrs.	500hrs. (250hrs. after first operation)	
Breaker work position	20% every 800 hrs.	300hrs.	1000hrs.
	40% every 400 hrs.		
	60% every 300 hrs.	100hrs.	
	More than 80% every 200 hrs.		

Suction filter should be checked when return filter and hydraulic oil are replaced.



Remove tank cover

1. Remove the hydraulic tank cover.
2. Pull out the filter support out off the hydraulic tank.
3. Remove the return filter from the filter support with a fork wrench and exchange the filter.

IMPORTANT;

- Always check the oil level when replacing the filter.

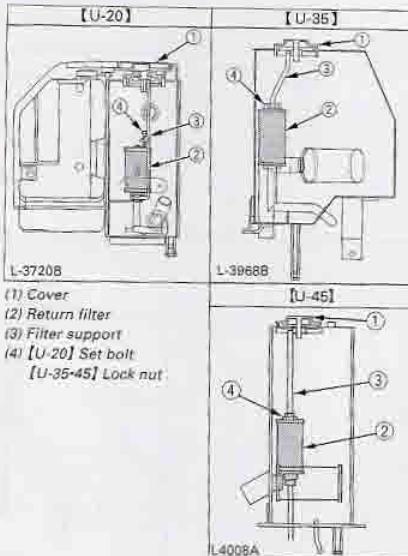

- (1) Cover
(2) Return filter
(3) Filter support
(4) [U-20] Set bolt
[U-35-45] Lock nut

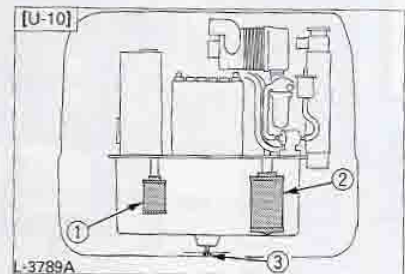

- 1) Suction filter 2) Return filter
3) Drain plug



CAUTION

For safe maintenance !

To avoid personal injury :

- Remove the oil filter only after the oil in the hydraulic tank has cooled down.

■ Return filter change...



● U-10,15 : Every 1000hrs.

U-20,35,45 : Initial 250hrs.

After 500hrs.

Suction filter change...Every1000 hrs.

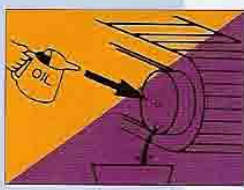
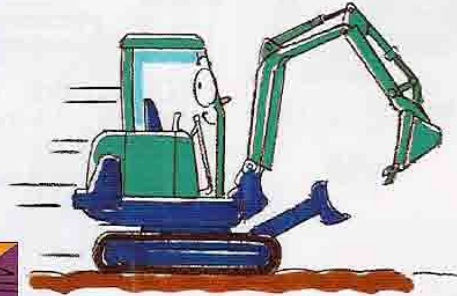
HYDRAULIC SYSTEM

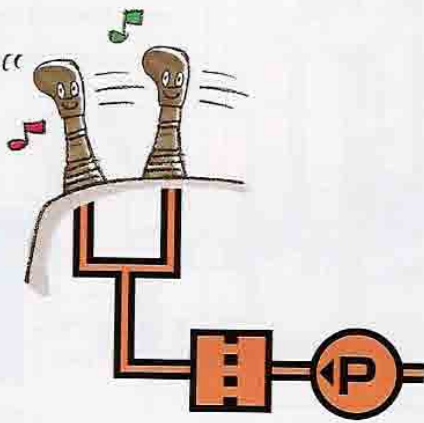
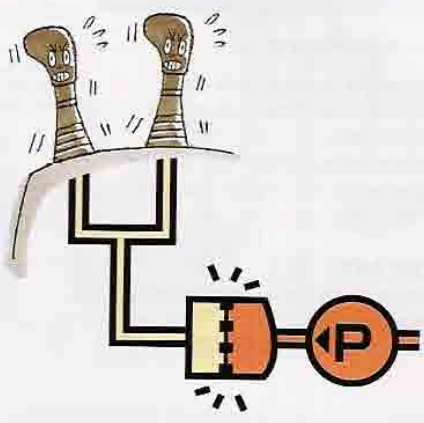
Item	Purpose	Fail symptom without maintenance
<p data-bbox="138 283 300 420">14</p> <p data-bbox="121 441 308 588">TRAVEL REDUCTION CASE GEAR OIL</p> 	<p data-bbox="503 294 673 325">Lubrication</p> 	 <p data-bbox="868 976 1291 1081">Shortage of oil causes oil temperature rise and seizure of inner parts. Contamination with dust or metal particle causes fatal damage of internal parts.</p>
<p data-bbox="138 1249 292 1396">15</p> <p data-bbox="121 1417 284 1512">PILOT FILTER</p>		

Inspection method

Adjusting/Refill/Change

U-15,20,35,45

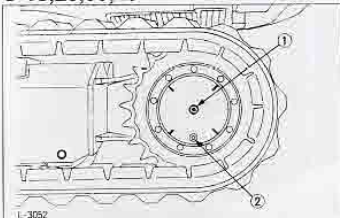

1) Oil check port 2) Drain plug

1. Rotate the crawler so that the drain plug of the drive unit is in the bottom position.
2. Remove the drain plug to let the oil run out. Screw in and tighten the drain plug again.
3. Refer to the table for gear oil quantities.
4. Use prescribed gear oil SAE 90.

One point advice!

Pictures below shows efficient way of oil filling.



1. Remove the plug.



1. Fill the oil until oil comes out of check port.

U-10

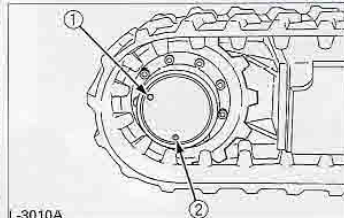

1) Oil observation port plug also serving as oil filling port.
2) Drain plug

1. Turn the crawler until the drive motors drain plug comes at the bottom.
2. Remove the plug in order to drain oil. After completing drain, plug the port (2)
3. Fill the gear oil through the oil filling port (1)



Travel motor position for oil filling and quantity checking



CAUTION

**For safe maintenance !
To avoid personal injury :**

- Lower attachments and stop the engine before undertaking the oil change.



New oil After 200 hrs. use...

L(us gal)

U-10	U-15	U-20	U-35	U-45
0.22 (0.06)	0.25 (0.07)	0.35 (0.09)	0.65 (0.17)	0.80 (0.21)

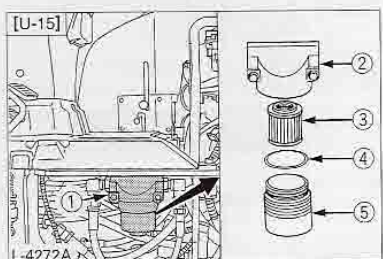

1)Hydraulic pilot filter 2)Head cover 3)Element
4)O-ring 5)Case

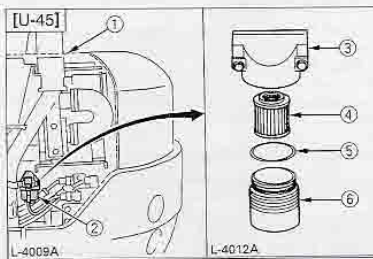

1)Arch cover 2)Hydraulic pilot filter 3)Head cover
4)Element 5)O-ring 6)Case

IMPORTANT:

- If the levers cannot be locked even by pulling up the control lever lock or the boom, arm, bucket, swivel and swing mechanisms do not function even with the control stand for the hydraulic pilot tilted forward, contact your KUBOTA dealer.

Pilot filter element kit (Element & O-ring)
U-15,45 : RD401-6127-0

- Element change interval...Every 1000hrs.

HYDRAULIC SYSTEM

Item 16 PILOT VALVE SCREEN CLEANING

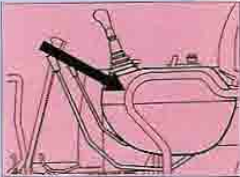

Purpose

Fail symptom without maintenance

Oil filtration from pump to pilot valve.



Clogged pilot filter causes pilot system malfunction.
Boom, arm, bucket, swivel, function may operate slow or not at all.

Rerommended oil, grease and fuel

	Application	Viscosity	Shell	Mobil	Exxon	MIL- Standard
Engine oil	In winter or by low temperature	SAE 10W	Shell Rotella T10W Shell Rimula 10W	Mobil Delvac 1310	XD-3 10W XD-3 Extra 10W	MIL-L-2104C MIL-L-2104D
		SAE 20W	Shell Rotella T20W-2 Shell Rimula 20W-2	Mobil Delvac 1320	XD-3 20W-20 XD-3 Extra 20W-20	
	In summer or by high ambient temperature	SAE 30	Shell Rotella T30 Shell Rimula 30	Mobil Delvac 1330	XD-3 30 XD-3 Extra 30	
		SAE 40	Shell Rotella T40 Shell Rimula 40	Mobil Delvac 1340	XD-3 40 XD-3 Extra 40	
ALL-season engine oil	Multi-purpose	Shell Rotella T15W		XD-3 15W-40 XD-3 Extra 15W-40		
Gear oil	In winter or by low temperature	SAE 75	Shell Oil S8643	Mobilube HD80W-90		MIL-L-2105C
		SAE 80	Shell Spirax HD80W	Mobilube HD80W-90		
	In summer or by high ambient temperature	SAE 90	Shell Spirax HD90	Mobilube 46 Mobilube HD80W-90		MIL-L-2105 MIL-L-2105C
		SAE 140	Shell Spirax HD140	Mobilube HD85W-140 Mobilube HD80W-140		MIL-L-2105C MIL-L-2105C
All-weather gear oil	Multi-purpose	Shell Spirax HD80W Shell Spirax HD85W	Mobilube HD80W-90	GX80W-90	MIL-L-2105C	
Hydraulic oil	In winter or by low temperature	ISO 32	Shell Tellus T32	Mobil DTE-Oil 13	NUTO H32	
		ISO 46	Shell Tellus T46	Mobil DTE-Oil 15	NUTO H46	
	In summer or by high ambient temperature	ISO 68	Shell Tellus T68	Mobil DTE-Oil 16	NUTO H68	
Grease		Shell Alvania EP2	Mobilux EP-2	BEACON Q2		
Fuel			Lite oil No. 2-D(ASTM D975)			
Fuel under -5°C (+23°F)			Lite oil No. 1-D(ASTM D975)			

Important

1. Oil used to fill the hydraulic system at the factory is ISO 46 viscosity grade.
2. Use CD-Grade according to API as engine oil.
3. Use SAE 90 (API.CLA/GL5)as drive unit oil for all seasons.

Inspection method

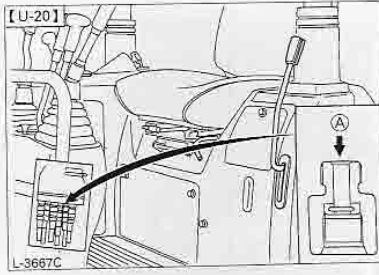

Pilot filter

Adjusting/Refill/Change

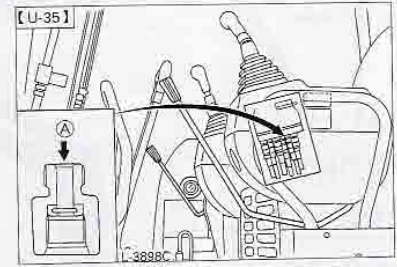

Contact your Kubota Dealer for cleaning.



■ Pilot filter clean...Every 1000 hrs.



CAUTION

For safe maintenance !
To avoid personal injury:
Stop engine. Relieve internal pressure,
otherwise oil may splash out.



Quantity Water and Oil

Item		Model	L				
			U-10	U-15	U-20	U-35	U-45
Soft water	Radiator		3.0 0.79	3.5 0.82	3.5 0.92	4.5 1.19	5.9 1.56
	Reserve tank		0.5 0.13	0.5 0.13	0.5 0.13	1.0 0.26	1.0 0.26
Engine oil	Engine crank case		2.5 0.66	2.6 0.69	4.0 1.06	4.5 1.19	8.0 2.11
Hydraulic oil	Operating oil tank	Full	17.0 4.49	23 6.08	33.0 8.72	56.0 14.80	95.0 25.10
		Tank	14.0 3.70	14.0 3.70	20.0 5.28	39.0 10.30	71.0 18.78
Gear oil	Wheel motor		0.22 0.06	0.25 0.07	0.35 0.09	0.65 0.17	0.8 0.21
	Swivel reduction gear case		—	—	—	—	—
	Track roller	Grease	0.008 0.002	0.025 0.007	0.035 0.009	0.05 0.013	0.11 0.029
	Front idler	Grease	0.011 0.003	0.03 0.008	0.035 0.009	0.07 0.018	0.04 0.011
Light oil	Fuel tank		9.5 2.51	18.0 4.76	24.0 6.34	32.0 8.45	57.0 15.06

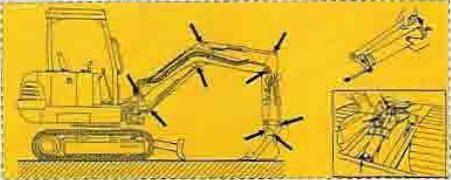
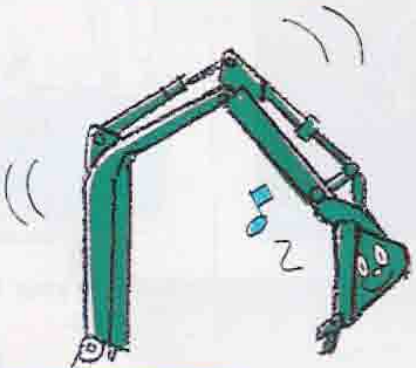
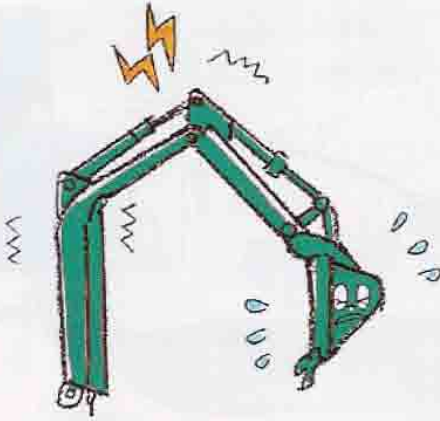
MACHINE BODY & ATTACHMENT

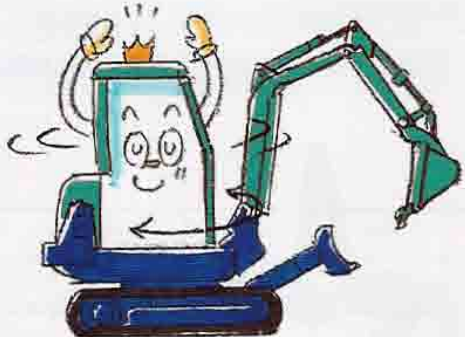
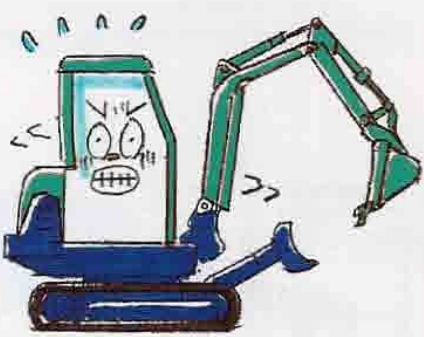
Item	Purpose	Fail symptom without maintenance
<p>17</p> <p>FRONT GREASING POINTS</p> 	<p>Smooth function</p> 	 <ul style="list-style-type: none"> ● Abnormal noise. ● Pin and bushing stick together. ● Excessive wear causes sluggish movement. Pin damage.

<p>18</p> <p>TEETH, BEARING, PILOT VALVE GREASING</p>	<p>Upper frame swivel function.</p> 	 <p>Swivel bearing and teeth stuck or causes abnormal noise and vibration.</p>
---	--	---

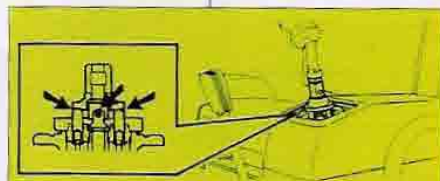
VARIABLE TRACK FRAME GREASING :U-10,15,20



Maintenance guide line of slide frame

Specific maintenance interval is not fixed. Still, in case of the following conditions, customers, operators or dealer service personnel are required to wash and clean the slide frame and apply grease all four sides.

Conditions :

- 1) When soil and mud are piled up.
- 2) When machine body and undercarrige are due to be washed by water or steam after rental use.
- 3) When periodical maintenance is carried out.
- 4) When machine is due a long storage.
- 5) When undercarrige is overhauled.



Inspection method

Adjusting/Refill/Change

Grease the grease nipples shown by arrows in the illustration.	Q'ty	U-15	U-10	U-20-45
1) Boom bottom linkage	1 place	Every 250hrs	Daily greasing	Daily greasing
2) Arm bottom linkage	1 place	Every 100hrs		
3) Bucket link pin	3 places	Every 250hrs		
4) Boom cylinder boss	2 places	Every 100hrs		
5) Arm cylinder boss	2 places	Every 250hrs		
6) Bucket cylinder boss	1 place	Every 250hrs		
7) Fixing pin between arm and bucket	1 place	Every 250hrs	No need to grease	
8) Boom swing fulcrum	1 place			
9) Swing cylinder boss	1 place			
10) Swing cylinder pin	1 place			
11) Dozer cylinder boss	2 places			
12) Dozer linkage pin	2 places			

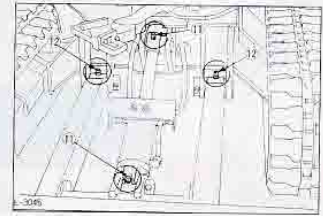
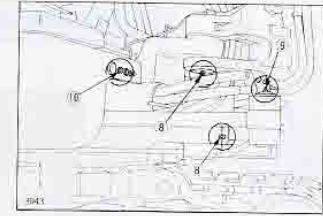
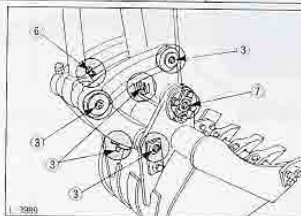
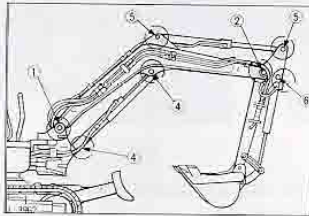

CAUTION

For safe maintenance!
Put the front attachment
down, stop engine.

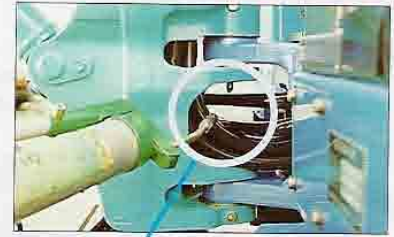

Greasing swing bracket pin bushing.

■ Inspection interval...Daily inspection item.

■ Greasing of Swing Bearing Teeth

1. Fill in grease through the grease nipple (at the right end side).
2. Fill with approx. 50g of grease (approx. 20 pumps with the grease gun. Distribute the grease over the teeth by swiveling the unit.

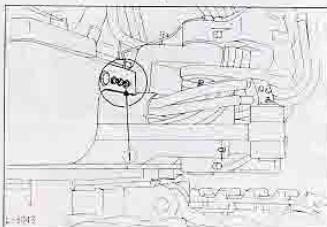

■ Greasing of the Swing Bearing

1. Grease through the respective grease nipple.
2. Grease at each 90° (1.58 rad.) position of the swing frame.

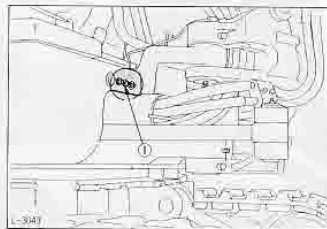

■ Lubrication of the Pilot Valve

Remove the rubber bellows from the underside of the control levers. Grease the tip of the push rod and the rotating part of the link.

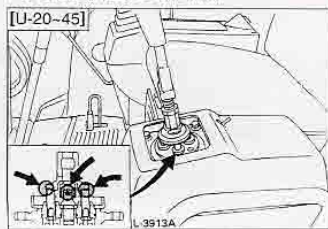

CAUTION

For safe maintenance!
Keep out any
person or obstacles.

U-10.....Mechanical lever
U-15.20...Front lever
U-35.45...Wrist lever



Grease four times at each 90 degree position of upper frame.

- Swivel teeth greasing
U-10-45 Every50 hrs.
- Swivel bearing greasing
U-10-45 Every200 hrs.
- Pilot valve greasing
U-15-45 Every200 hrs.

MACHINE BODY & ATTACHMENT

Item	Purpose	Fail symptom without maintenance
------	---------	----------------------------------

19

FRONT IDLER & TRACK ROLLER

Travel shock absorber on rough terrain

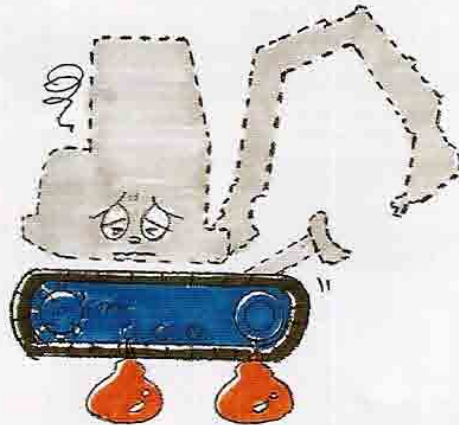
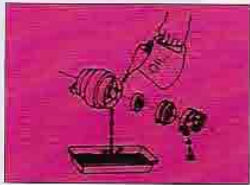
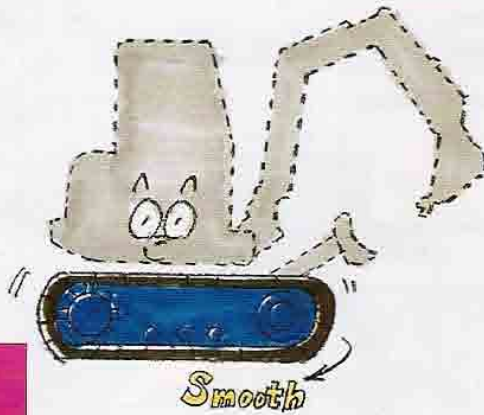

Oil shortage or leakage cause bearing seizure or fatal damage.

20

TRACK TENSION ADJUSTMENT

Smooth travelling

Flotation on soft ground

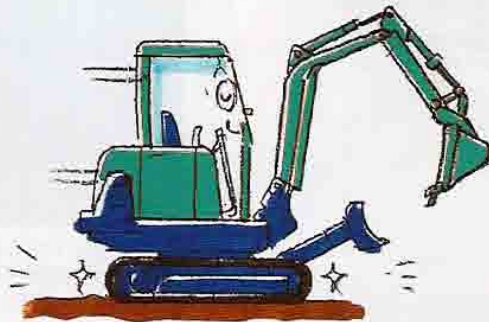

Rubber track & iron track

- Loose tension causes track coming off, cutting or severe damage.
- Tight tension causes excessive wear of sprocket and shoe link or track cutting.

Inspection method



Oil leakage out of track roller

Adjusting/Refill/Change

Contact Kubota Dealer for maintenance.



L(us gal)

Model	U-10	U-15	U-20	U-35	U-45
Track roller	0.008 (0.002)	0.025 (0.007)	0.035 (0.009)	0.05 (0.013)	0.11 (0.029)
Front idler	0.011 (0.003)	0.03 (0.008)	0.035 (0.009)	0.07 (0.018)	0.04 (0.011)

Change interval...Every2000hrs.

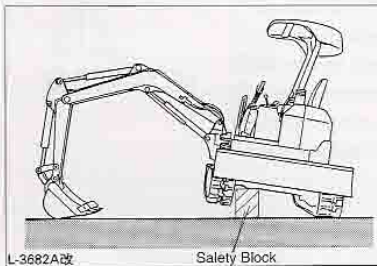

L-3682A改

Safety Block



Actual measurement



Crawler seam should be positioned at the top in the center position.

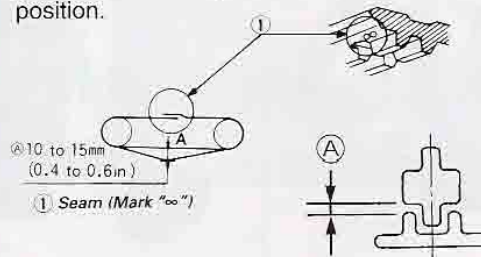

Adjust track tension by applying grease into grease nipple.
Note:FMachine should be raised with tracks hanging free.

Track tension mm(in.)

Model	U-10	U-15	U-20	U-35,40
Rubber	8-13 (0.3-0.5)		10-15 (0.4-0.6)	
Iron	—	—	30-35 (1.18-1.38)	40-45 (1.57-1.78)



CAUTION

For safe maintenance!

To avoid personal injury:

- Do not loosen the grease nipple completely or too quickly. Otherwise grease under high pressure in the tension cylinder

could squirt out.

- Make sure that no obstruction, such as stones are caught in the crawler. Remove such obstructions before adjusting the crawler tension.

Daily inspection item

MACHINE BODY & ATTACHMENT

Item	Purpose	Fail symptom without maintenance
------	---------	----------------------------------

21

BUCKET TEETH & SIDE CUTTER

Penetrate and dig the soil.



Worn teeth & side cutter won't dig the soil or will make digging surface rough.

22

BOLTS & NUTS CHECKING OF MUFFLER ROPS/FOPS CAB & CANOPY

Fix and keep rigid the components.

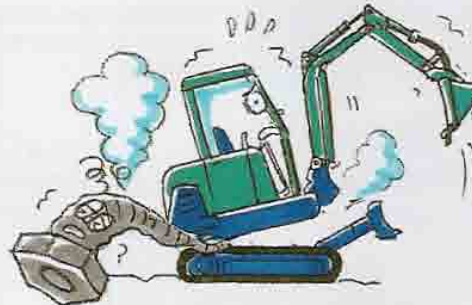

- Bolts & nuts: Loosened or coming off.
- Muffler: Causes abnormal noise or smoking.
- Rops/Fops: Loosened, may cause fatal injury.

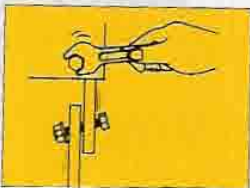

Inspection method

Adjusting/Refill/Change

ADJUSTMENT OF LOOSE BUCKET [JPN BUCKET VERSION]

Should the bucket become loose, adjust according to following steps.

- 1) Loosen the bucket bolts with a wrench.
- 2) Loosen the bolt of the fixing plate in the same manner.
- 3) Remove both shims and knock in the pin heads until the play is adjusted to under 1mm. (The shim has a thickness of 1mm (0.04 in.))
- 4) Tighten the fixing plate bolts first, then the bucket bolts.

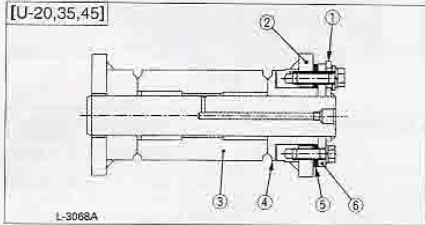

- 1) Bucket pin 2) Bucket 3) Arm
- 4) Movable boss 5) Shim 6) Fixing plate

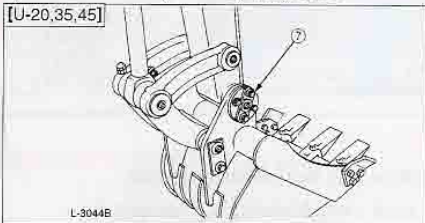

- 7) Fixing plate bolts

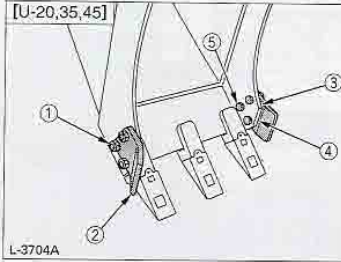

- 1) Nut 2) Mounting bolt 3) Side cutters

Side cutter bolt tightening torque /kgm(lbs)

	26.5~31kgf·m
U-20,35,45	192~224ft·lbs
	260~304N·m



CAUTION

For safe maintenance!

To avoid personal injury:

- Wear eye protection when changing the tooth points.

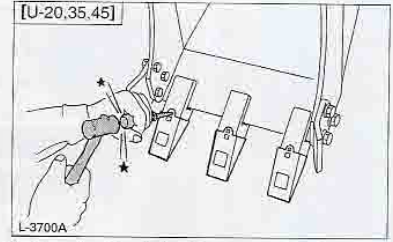

- 1) Rubber plug 2) Lock pin 3) Pointcutters 4) Tooth adapter

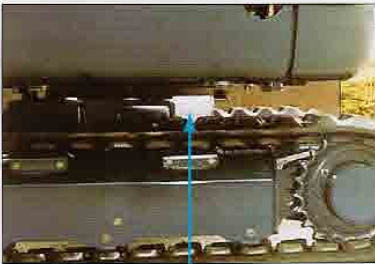
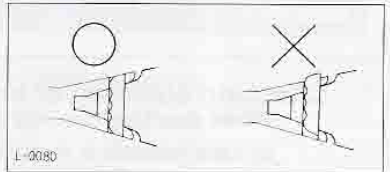
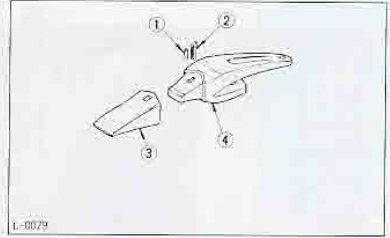

Swivel bearing mounting bolts.



CAUTION

Stop engine! Use proper tool and use standard service procedure.

For important tightening torque and proper inspection, contact your Kubota Dealer.



Important tightening torque table

[N·m, kgf·m, ft.lbs.]

[N·m, kgf·m, ft.lbs.]

Item	Model	*1	U-10	U-15	U-20	U-35	U-45
1	Traveling motor	Locktite 271	48.1-55.1 4.9-5.7 35.4-41.2	60.8-70.6 6.2-7.2 44.8-52.1	103-117.7 10.5-12 75.9-86.8		
2	Sprocket	Locktite 271	48.1-55.1 4.9-5.7 35.4-41.2	60.8-70.6 6.2-7.2 44.8-52.1	103-117.7 10.5-12 75.9-86.8		
3	Gressa cylinder nipple	—		98-107.8 10-11 72.3-79.6			
4	Swivel bearing	Locktite A 271		103-117.7 10.5-12 75.9-86.8		260-304 26.5-31 191.7-224.2	
5	Swivel motor	Locktite A 271	77.5-90.2 7.9-9.2 57.1-66.5	48.1-55.9 4.9-5.7 35.4-41.2	116.7-196.1 17.0-20.0 123.0-144.7	198.1-225.6 20.0-23.0 144.7-166.3	
6	Return filter	—		49.0-59.0 5.0-6.0 36.2-43.4		68.6-78.5 7.0-8.0 50.6-57.9	
7	Engine shock absorber	Locktite 271	48.1-55.1 4.9-5.7 35.4-41.2	39.2-45.1 4.0-4.6 28.9-33.3	48.1-55.1 4.9-5.7 35.4-41.2	77.5-90.2 7.9-9.2 57.2-66.5	No.1 No. 2 No.3 80 165-191 100 170-195 123 223-141
8	Engine bracket	—	48.1-55.1 4.9-5.7 35.4-41.2	—	48.1-55.1 4.9-5.7 35.4-41.2	*2	
9	Engine support	—	48.1-55.1 4.9-5.7 35.4-41.2	—	48.1-55.1 4.9-5.7 35.4-41.2	77.5-90.2 7.9-9.2 57.2-66.5	48.1-55.9 4.9-5.7 35.4-41.2

Item	Model	*1	U-10	U-15	U-20	U-35	U-45
10	Weight protector	—	77.5-90.2 7.9-9.2 57.2-66.5	123.6-147.1 12.6-15.0 91.1-108.5	48.1-55.9 4.9-5.7 35.4-41.2	519.8-588.8 53.0-58.0 383.3-419.5	367.7-431.5 37.5-44.0 271.2-318.2
11	Starler motor (terminal nut)	—				6.1-12.0 0.6-1.2 4.3-8.7	
12	Swivel stopper bolt	Locktite 271	—		48.1-55.9 4.9-5.7 35.4-41.2		
13	Bucket side cutter	Locktite 271	—		215.7-248.2 22-25 159.1-180.8	260-307 26.5-31.0 192-224	
14	Cylinder head cover	—		3.9-5.9 0.4-0.6 2.89-4.34		6.9-8.8 0.7-0.9 5.06-6.51	
15	Nozzle holder	—			49.1-68.7 5.0-7.0 36.2-50.6		
16	Cylinder head bolt	—	37.3-42.2 3.8-4.3 27.5-31.1		63.7-68.6 6.5-7.0 47.0-50.6	93.2-98.1 9.5-10.0 68.7-72.3	
17	Connecting rod bolt	—	26.5-30.4 2.7-3.1 19.5-22.4		41.2-46.1 4.2-4.7 30.4-34.0	46.1-51.0 4.7-5.2 34.0-37.6	
18	Fly wheel	—		53.9-58.8 5.5-6.0 39.8-43.4		98.1-107.9 10.0-11.0 72.3-79.6	

*1 Apply locking adhesive (lockite) to the **A** important process control items. Unless otherwise specified, use three bond 1324 for screw adhesive.

*2 Bracket 1.2
77.5-90.2
7.9-9.2
57.1-66.5
Bracket 3.4
123.6-147.1
12.6-15.0
91.1-108.5

Checking standard of bolt & nut looseness.

When checking the bolt & nut tightening conditions by wrench, follow the below judgement.

In case wrench is turned, it means loosening. Therefore, in that case retightening to torque is required.

Screw size	Force applied on wrench	Bolt head width	Wrench length
M6	4~ 5 kg	Force by grip	Approx. 130mm
M8	6~ 9	Force from elbow	// 140
M10	10~15	Force from shoulder	// 165
M12	14~20	Upper body force	// 210
M16	30~41	Total body force	// 245
M20	47~68	Total body weight & force	// 280

Tightness torque of bolts & nuts

Bolts, Nuts Boulons, Ecrous Schrauben, Muttern	4T (4)	7T (7)	9T (9)
	SS41	S40C, S45C	SCr4
M6	7.8-9.3 N·m 0.80-0.95kgf·m, 5.8-6.9ft.lbf	9.8-11.3 N·m 1.00-1.15kgf·m, 7.2-8.3ft.lbf	12.3-14.2 N·m 1.25-1.45kgf·m, 9.0-10.5ft.lbf
M8	17.7-20.6 N·m 1.80-2.10kgf·m, 13.0-15.2ft.lbf	23.5-27.5 N·m 2.40-2.80kgf·m, 17.4-20.3ft.lbf	29.4-34.3 N·m 3.00-3.50kgf·m, 21.7-25.3ft.lbf
M10	39.2-45.1 N·m 4.00-4.60kgf·m, 28.9-33.3ft.lbf	48.0-55.9 N·m 4.90-5.70kgf·m, 35.4-41.2ft.lbf	60.8-70.6 N·m 6.20-7.20kgf·m, 44.8-52.1ft.lbf
M12	62.8-72.6 N·m 6.40-7.40kgf·m, 46.3-53.5ft.lbf	77.5-90.2 N·m 7.90-9.20kgf·m, 57.1-66.5ft.lbf	103.0-117.7 N·m 10.50-12.00kgf·m, 75.9-86.8ft.lbf
M14	107.9-125.5 N·m 11.00-12.80kgf·m, 79.6-92.6ft.lbf	123.6-147.1 N·m 12.60-15.00kgf·m, 91.1-108.5ft.lbf	166.7-196.1 N·m 17.00-20.00kgf·m, 123.0-144.7ft.lbf
M16	166.7-191.2 N·m 17.00-19.50kgf·m, 123.0-141.0ft.lbf	196.1-225.6 N·m 20.00-23.00kgf·m, 144.7-166.4ft.lbf	259.9-304.0 N·m 26.50-31.00kgf·m, 191.7-224.2ft.lbf
M18	245.2-284.4 N·m 25.00-29.00kgf·m, 180.8-209.7ft.lbf	274.6-318.7 N·m 28.00-32.50kgf·m, 202.5-235.1ft.lbf	343.2-402.1 N·m 35.00-41.00kgf·m, 253.2-296.5ft.lbf
M20	333.4-392.2 N·m 34.00-40.00kgf·m, 245.9-389.3ft.lbf	367.7-431.5 N·m 37.50-44.00kgf·m, 271.2-318.2ft.lbf	490.3-568.8 N·m 50.00-58.00kgf·m, 361.6-419.5ft.lbf

U-15 Maintenance Intervals

Checkpoints	Hour meter indicator																	Consequently						
	Intervals	50	100	150	200	250	300	350	400	450	500	550	600	650	700	750	800		850	900	950	1000		
ENGINE	1 ENGINE OIL	daily check																						every 100 hrs
		change	●		●		●		●		●		●		●		●		●		●		●	every 200 hrs
	2 OIL FILTER	change	●				●				●				●				●				●	every 200 hrs
	3 COOLANT	daily check																						every 2 years
		change																						rinsed every 2 years
	4 RADIATOR	daily check																						every 200 hrs
		change																						every 2 years
	5 RADIATOR HOSES AND CLAMPS	check				●				●					●				●				●	every 200 hrs
		change																						every 2 years
	6 FAN BELT TENSION	adjust				●				●					●				●				●	every 200 hrs
	7 AIR CLEANER ELEMENT	Outer clean				●				●					●				●				●	every 200 hrs
		Outer change																						every 1000 hrs
	8 FUEL FILTER	Inner clean		●		●		●		●		●		●		●		●		●		●		every 100 hrs
change											●											●	every 500 hrs	
9 FUEL TANK	drain water	●	●	●	●	●	●	●	●	●	●	●	●	●	●	●	●	●	●	●	●	●	every 50 hrs	
10 FUEL HOSE	check				●				●					●				●				●	every 200 hrs	
	change																						every 2 years	
11 BATTERY	check	●	●	●	●	●	●	●	●	●	●	●	●	●	●	●	●	●	●	●	●	●	every 50 hrs	
12 WIRE HARNESS & FUSES	daily check																						annual servicing	
13 DYNAMO AND STARTER MOTOR	check																						every 2000 hrs	
HYDRAULIC SYSTEM	14 HYDRAULIC OIL	daily check																					every 1000 hrs	
		change																				●	every 1000 hrs	
	15 HYDRAULIC RETURN FILTER	change																				●	every 1000 hrs	
	16 HYDRAULIC SUCTION FILTER	change																				●	every 1000 hrs	
	17 TRAVEL REDUCTION CASE GEAR OIL	change		●										●									●	every 500 hrs
18 HYDRAULIC PILOT FILTER ELEMENT	change																					●	every 1000 hrs	
MACHINE BODY & ATTACHMENT	19 BUEKT PINS AND BUSHING	check		●		●		●		●		●		●		●		●		●		●	every 100 hrs	
	20 SWIVEL HEADING TEETH	grease	●	●	●	●	●	●	●	●	●	●	●	●	●	●	●	●	●	●	●	●	every 50 hrs	
	21 SWIVEL BALL BEARING	grease				●				●				●				●				●	every 200 hrs	
	22 PILOT VALVE PUSHROD AND LINK	grease				●				●				●				●				●	every 2000 hrs	
	23 FRONT IDLER OIL	change																				●	every 2000 hrs	
	24 TRACK ROLLER OIL	change																						
	25 TRACK TENSION	daily check																						
	26 BUCKET TEETH	daily check																						
	27 SIDE CUTTER & BOLT	daily check																						
	28 BOLTS & NUTS	daily check																						
	29 MAFFLER & BOLT	daily check																						
	30 CAB & CANOPY	daily check																						

● Initial maintenance item
 After completing maintenance job, fill in the checking mark ✓

Kubota Corporation Construction Machinery Sales & Service Network

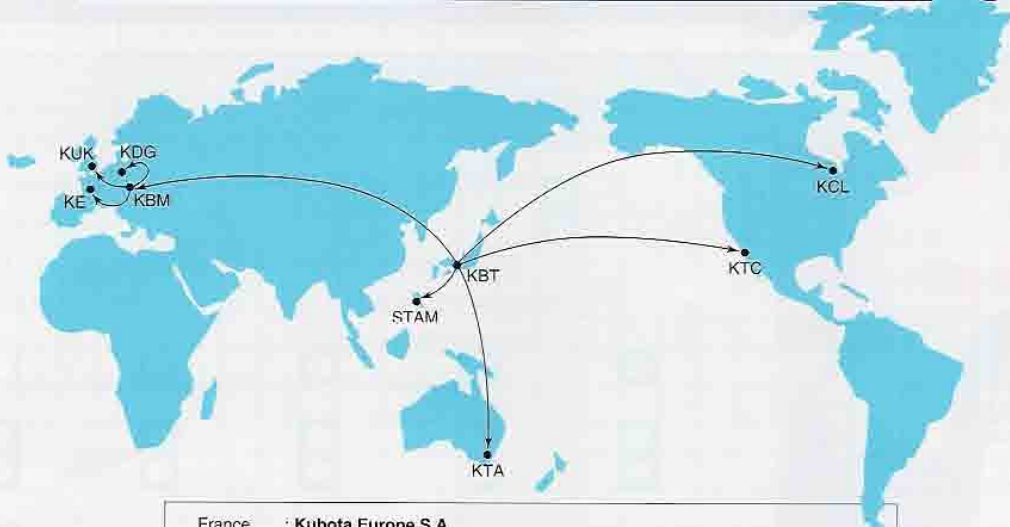

- France : **Kubota Europe S.A.**
19-25, rue Jules Verceyruisse Z.I. BP88, 95101 Argenteuil Cedex, France
- Germany : **KUBOTA (DEUTSCHLAND) GmbH**
Senefelder Str. 3-5 83110 Rodgau / Nieder-Roden, Germany
- : **KUBOTA Baumaschinen GmbH**
Stein hauser Str.100,66482 Zweibückerzn,Reinlaudptalz,Germany
- U.K. : **KUBOTA (U.K.) LTD.**
Dormer Road, Thame, Oxfordshire, OX9 3UN, U.K.
- U.S.A : **KUBOTA TRACTOR CORPORATION**
3401 Del Amo Blvd. Torrance CA 90503 U.S.A.
Telephone : (310)370-3370
- Canada : **KUBOTA CANADA LTD.**
1495 Denison Street. Markham, Ontario, L3R 5H1, Canada
Telephone : (905)475-1090
- Australia : **KUBOTA TRACTOR (Australia)PTY., LTD.**
100 Kellor Park Drive, Tullamarline ,Victoria 3043, Australia
- Taiwan : **SHIN TAIWAN AGRICULTURAL MACHINERY CO., LTD.**
16, Fengping 2nd Road Taliao Shiang Kaohsiung Hsien, 83107, Taiwan R.O.O.
- Japan : **KUBOTA Corporation**
Construction Machinery Export Department
2-47, Shikituhighashi 1-chome, Naniwa-ku, Osaka, Japan 556-8601

Construction Machinery Manufacturing Dept. Service Section 1-1-1 Nakamiya Oike Hirakata-shi,
Osaka Japan 573-8573 Telephone : 81-72-840-1195 Fax : 81-72-840-1195

DEALER SERVICE

Your KUBOTA dealer is always ready to help you to ensure that your excavator offers the best performance. After having carefully read these instruction, you will realize that much of the routine maintenance can be done by yourself. Your KUBOTA dealer is responsible for servicing and the delivery of spare parts. When ordering spare parts from your KUBOTA dealer, always mention the serial number of the excavator and engine. Note these numbers right away in the supplied lines.

	TYPE	Number
Excavator _____		_____
Engine _____		_____
Dealer's name _____ (To be filled in by the owner)		

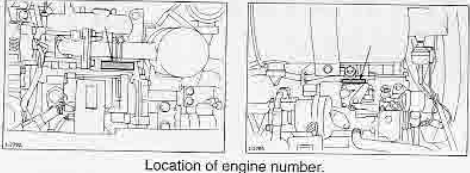

Location of engine number.

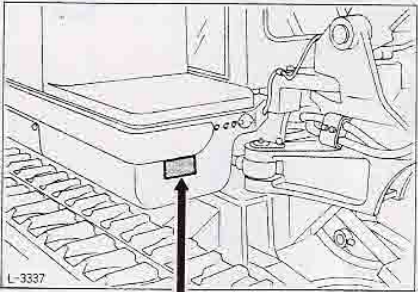

EXCAVATOR

MODEL	
SERIAL NO.	
ENGINE NO.	

KUBOTA Corporation JAPAN